

Ultra-Low Power Radio Technologies

Iain Thayne, Khaled Elgaid, Harold Chong, Martin Holland,
Helen McLelland, David Moran, Stephen Thoms, Colin Stanley

*Ultrafast Systems Group,
Nanoelectronics Research Centre,
University of Glasgow, G12 8LT, Scotland UK
ithayne@elec.gla.ac.uk*

The "5Cube"

5mm x 5mm x 5mm Speck

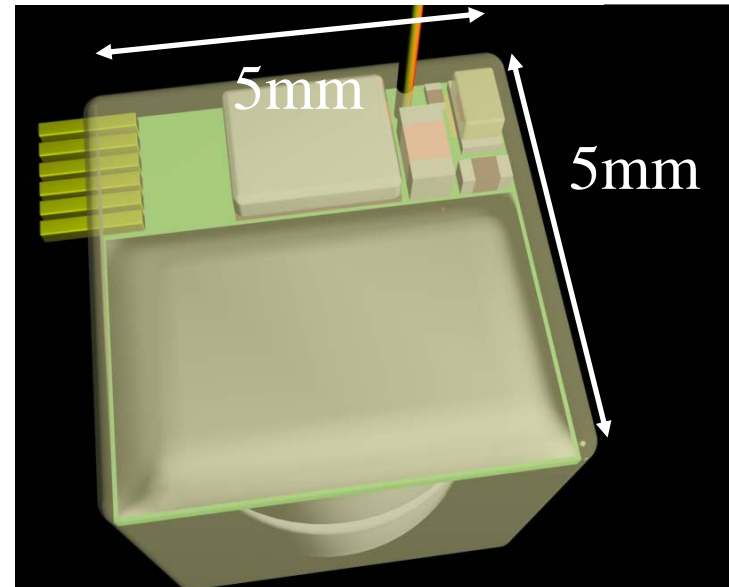
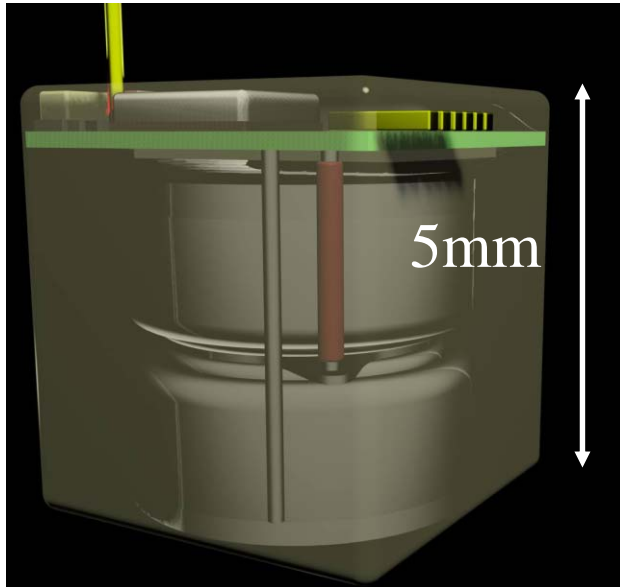

Majority of the volume is used by battery
Even then, constrained to $< 1\text{mW}$ for whole node
 $\sim 400 \mu\text{W}$ radio

The "5Cube" PCB

Key Radio Challenges

Low Power => Reduce Operating Frequency
Power Added Efficiency, Noise
Path Loss

Small Area => Increase Operating Frequency
MMIC Chip and Antenna Size

Fortunately, low data rate on-off keying is sufficient

Why Glasgow ?

Complete in-house III-V device capability

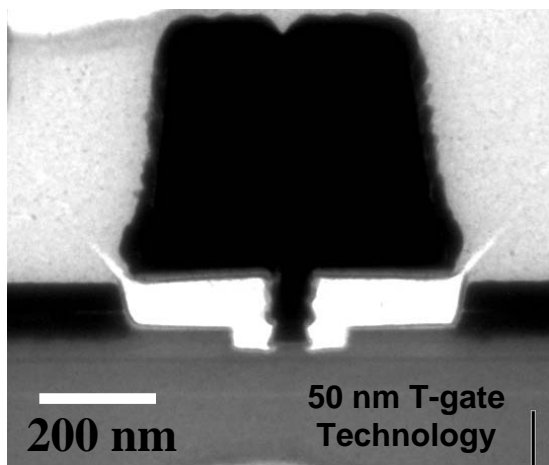

MBE Layer Growth

Marker Pattern

Ohmic Pattern, Anneal

Isolation Pattern

Gate Pattern, Etch



MBE Machines

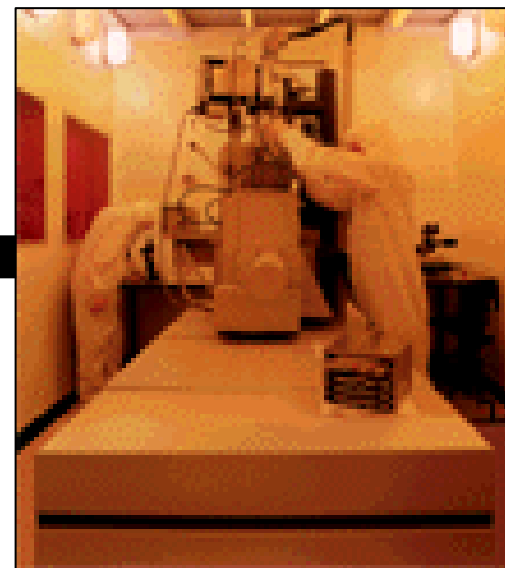

Direct Write Electron Beam Lithography

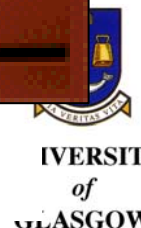

UNIVERSITY
of
GLASGOW

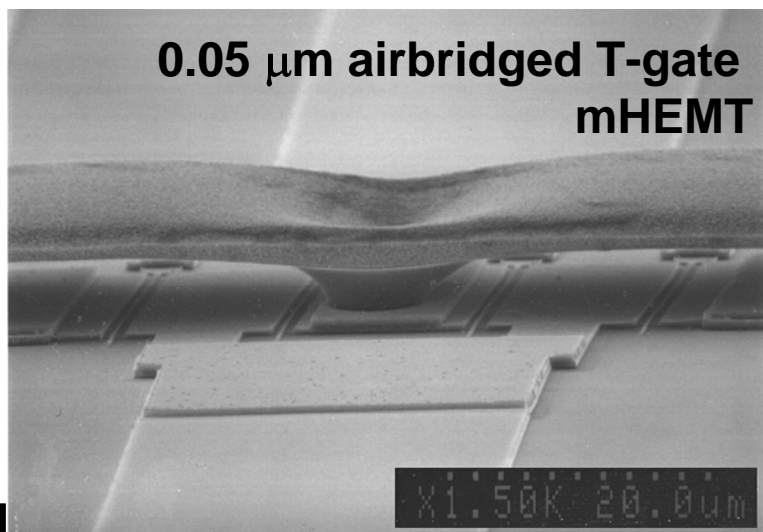
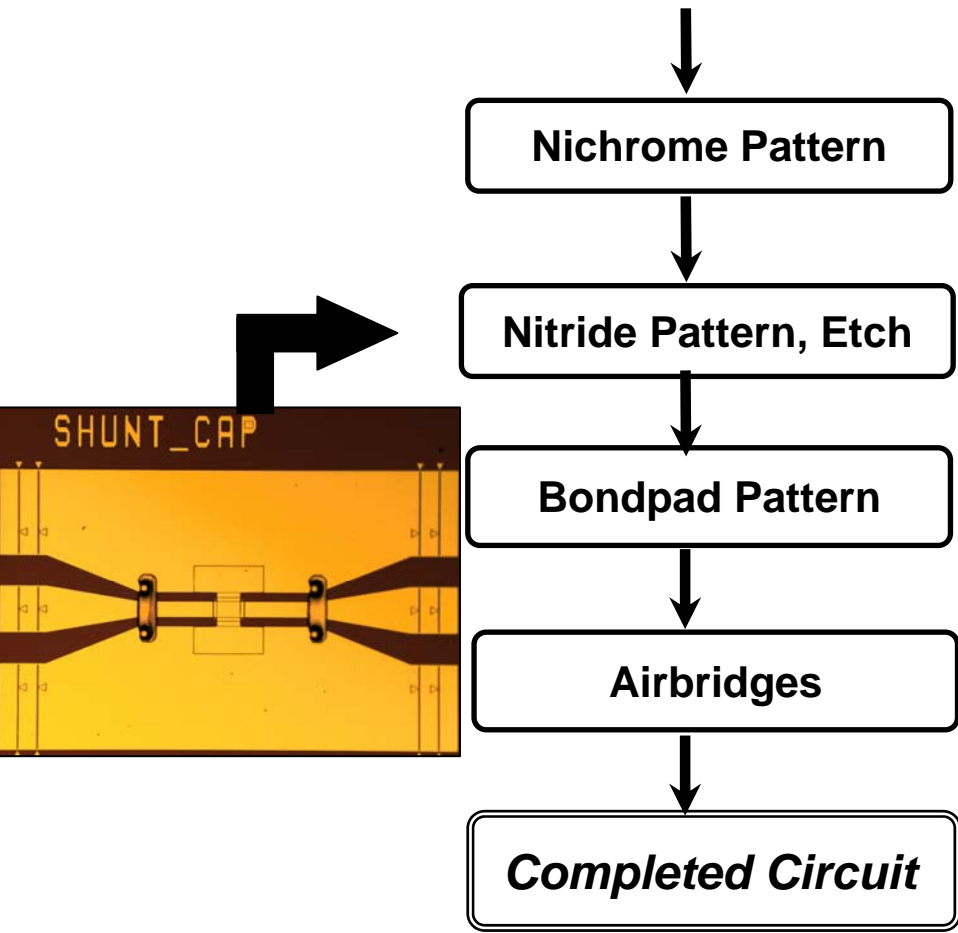

Micrograph of typical airbridged HEMT

V-Band Test
0.24-60GHz

W-Band Test
67-110GHz

On-Wafer mmWave
Testing to 110GHz

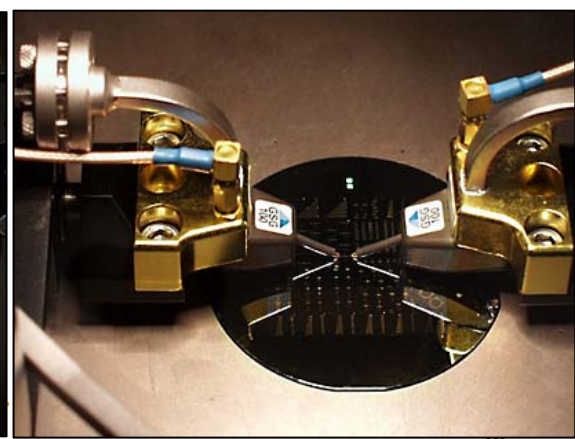
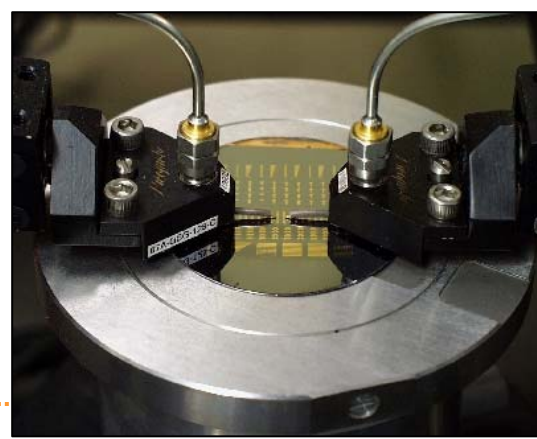

50 nm III-V Transistor Technology

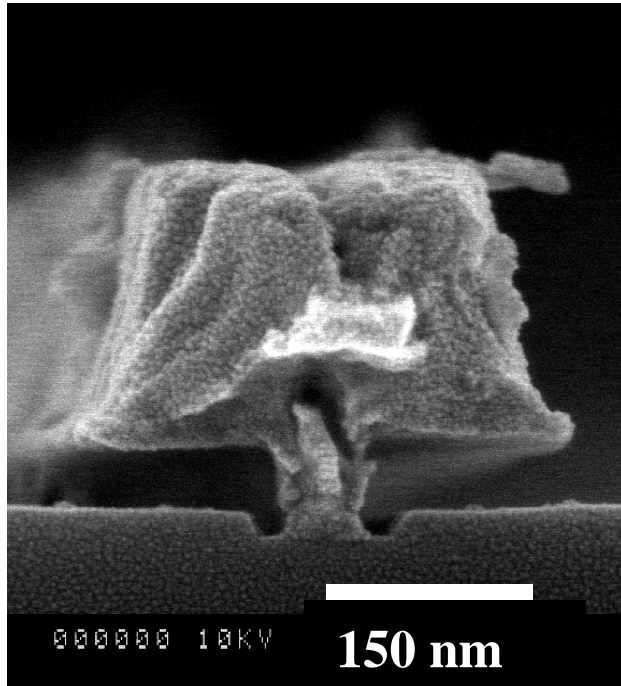

- Fastest
 - Lowest Noise
- GaAs Transistor Technology
in the World**

Metamorphic GaAs High Electron Mobility Transistors

Sample 54 devices Mean : 569 $\mu\text{A}/\mu\text{m}$
96% functional yield St Dev : 40 $\mu\text{A}/\mu\text{m}$

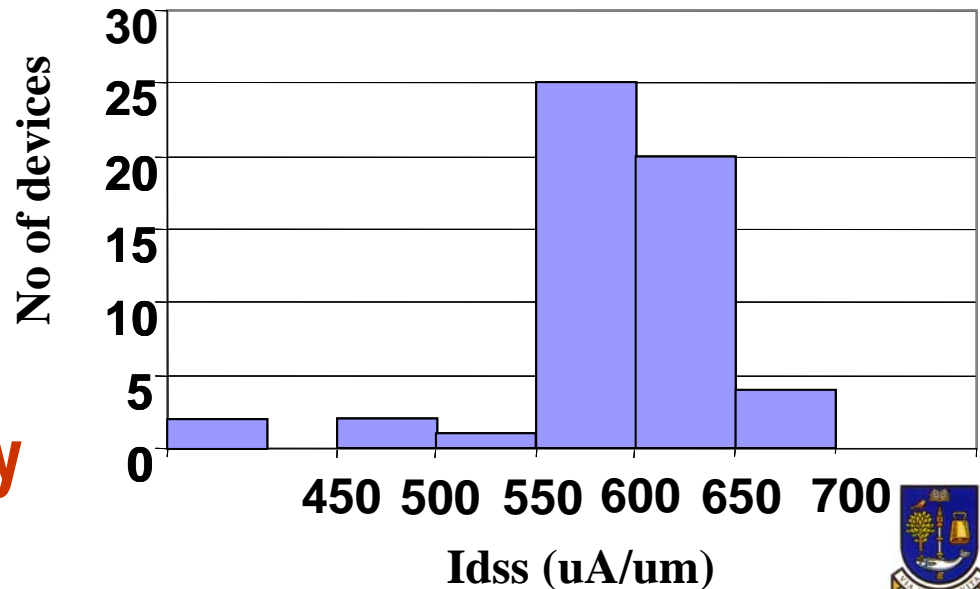

RF Characteristics II

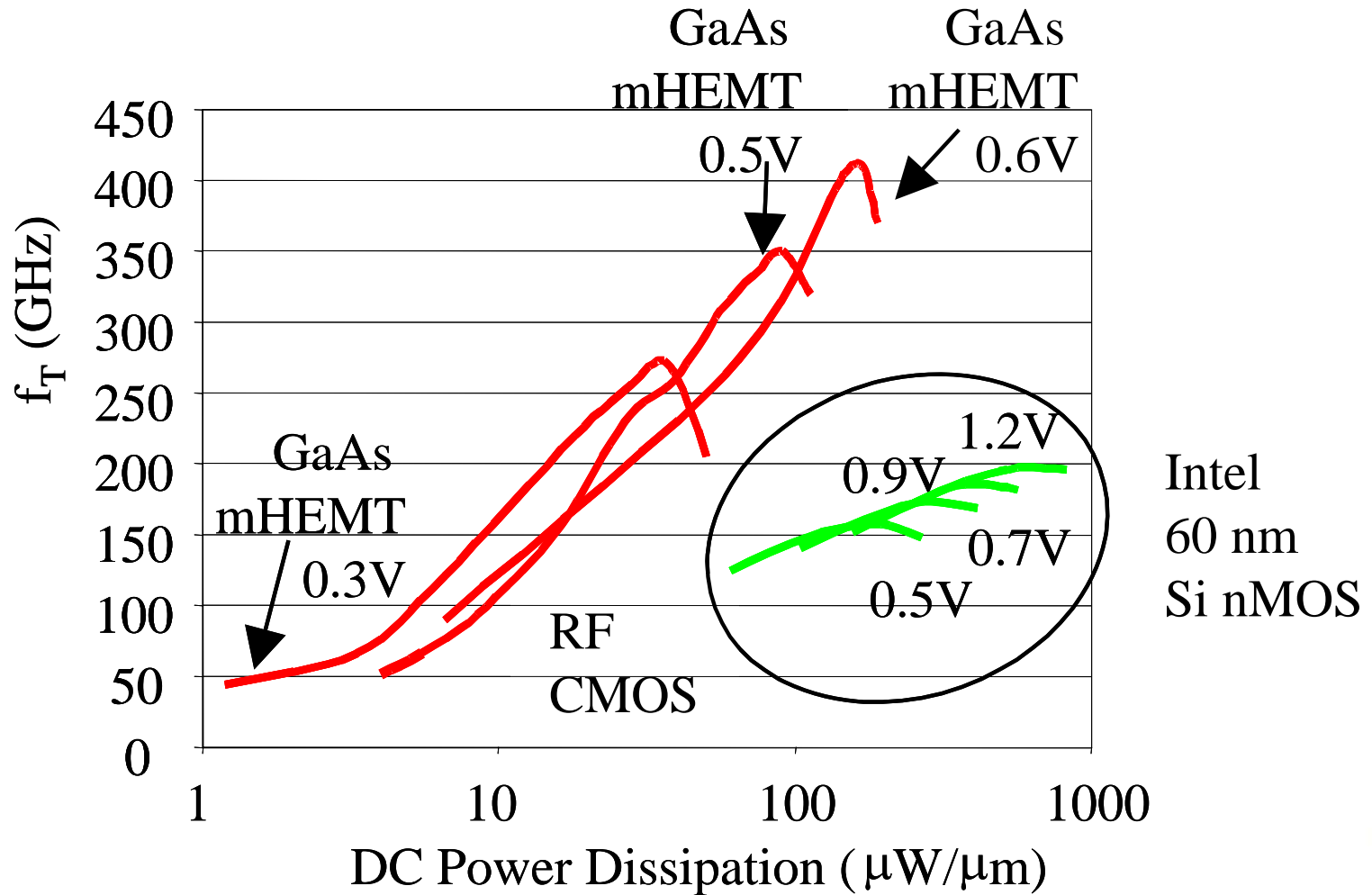

Intel
60 nm
Si nMOS

24 GHz ISM Band Radio sub-systems I

CPW Fed patch antenna 1.4 mm x 2.0 mm

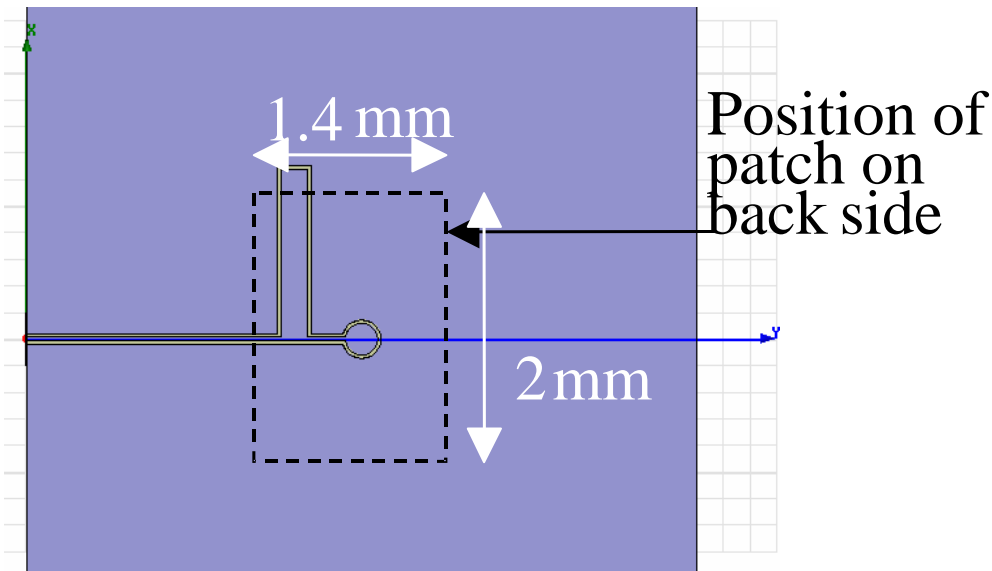

(1)

CPW Waveguide Feed

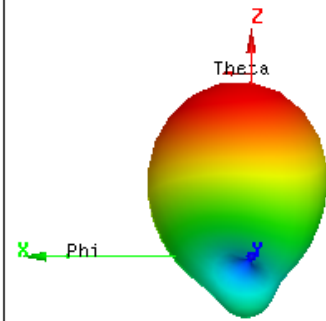
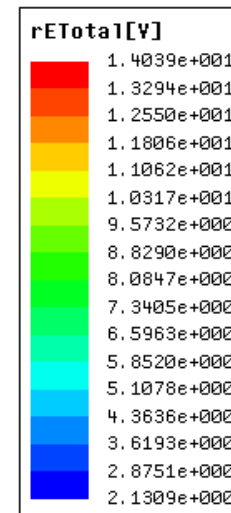
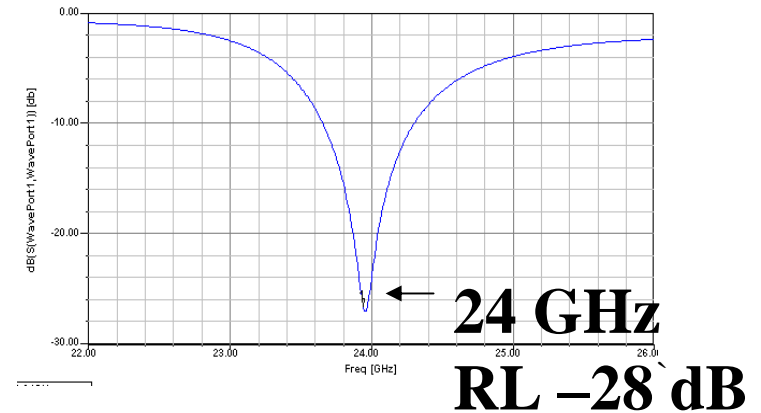

(1)



24 GHz ISM Band Radio sub-systems II

Single HEMT LNA

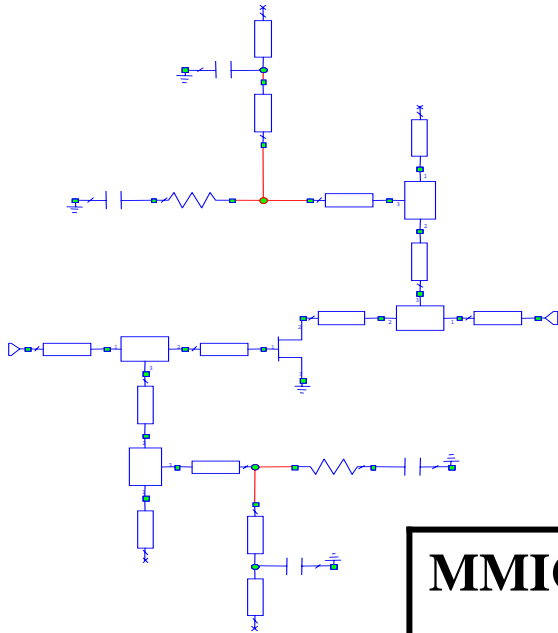

Single HEMT Oscillator

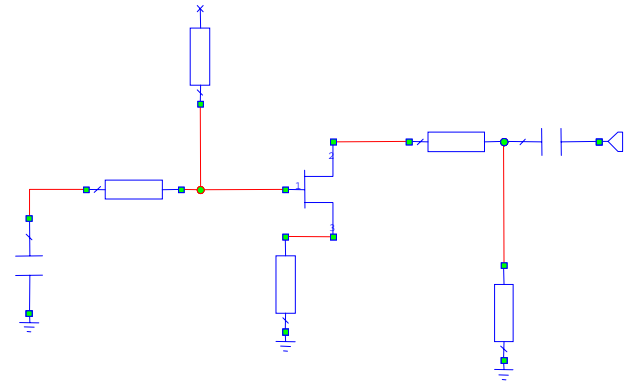

MMIC	Spec	P _{DC} (uW)	Size(mm x mm)
LNA	7 dB Gain < -6 dB Match	300	1.0 x 2.5
Oscillator	-10 dBm	300	2.0 x 1.5

Fully Integrated Transceiver

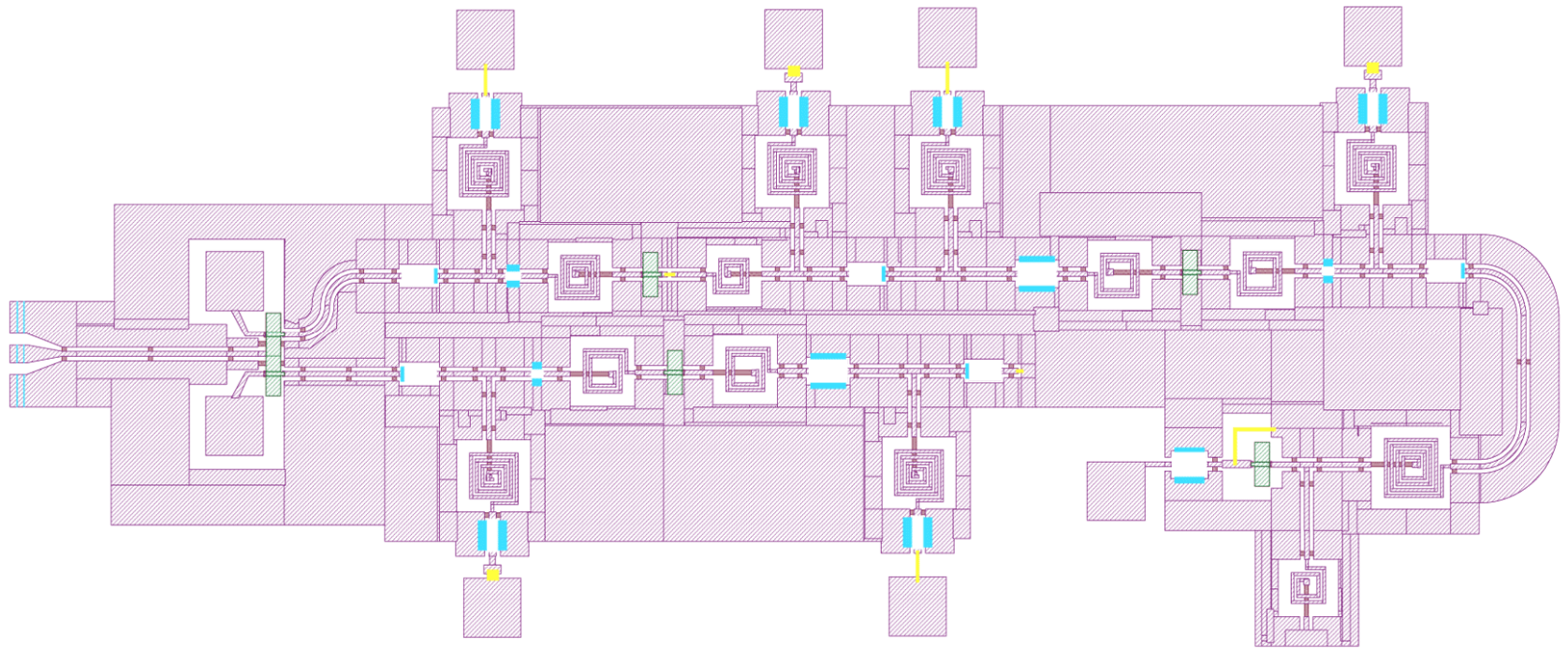

~ 5 mm x 2.2 mm

TX Power Consumption : 500 μ W (no duty cycle)

RX Power Consumption : 800 μ W (no duty cycle)

Conclusions

5 mm³ Specks put stringent constraints on radio transceiver

Scaled 50 nm GaAs mHEMTs offer superior performance to RF CMOS

300 uW radios seem feasible with modest duty cycling

Single duplex

On-Off Keyed Modulation

Direct Carrier Modulation at Transmitter

Super-Regenerative Receivers

24 GHz ISM will enable integrated transceiver and antenna in 5mm²